

MGG

开口式管全位置 自动焊接系统

All position of open pipe Automatic welding system

Dynaweld®
Group of companies

产品描述

- 全位置焊接方式
- 自熔或填丝
- 配备自动测速反馈系统，哈弗夹具，安装方便快捷
- 具备自动弧长和横摆及焊接跟踪功能
- 适用于碳钢、不锈钢等的管道材质焊接，配备外置送丝机构
- 机身轻便小巧，方便移动
- 多层焊接，清洁无焊渣，合格率高
- 全机水冷，多路气体保护，经久耐用
- 智能数字化控制，好用易学

FEATURES

- All position welding method
- Self melting or filling
- Equipped with automatic speed measuring feedback system and haft clamp, easy and quick installation
- Automatic arc length, yaw and welding tracking function
- It is suitable for welding of steel and stainless steel pipes, and equipped with external wire feeding mechanism
- The body is light and small, and it is easy to move
- Multi layer welding, clean and free of welding slag, high qualification rate
- Water cooling, multi-channel gas protection, durable
- Intelligent digital control, easy to learn

工程案例

PROJECT EXAMPLE



应用现场

ON-SITE PROCESS



可焊工件
Weldable workpiece



技术参数

TECHNICAL PARAMETER

型号 Model	适用管径 Diameter (mm)	适用壁厚 thickness (mm)	保护气体 Shielding gas	钨极规格 Tungsten electrode	焊枪重量 Weight (kg)	尺寸Size(mm)					
						A	B	C	D	E	F
MGG-90	Φ19-89	3-10	氩气Argon	2.4	6	92	165	230	382	135	337
MGG-170	Φ63-168	3-10	氩气Argon	2.4	10	172	280	340	382	160	453
MGG-230	Φ114-230	3-10	氩气Argon	2.4	24	235	400	425	437	165	620
MGG-325	Φ159-325	3-10	氩气Argon	2.4	36	328	500	550	497	181	730

- 搭载MWA-400一体化控制焊接电源~
Equipped with MWA-400 integrated control welding power supply~

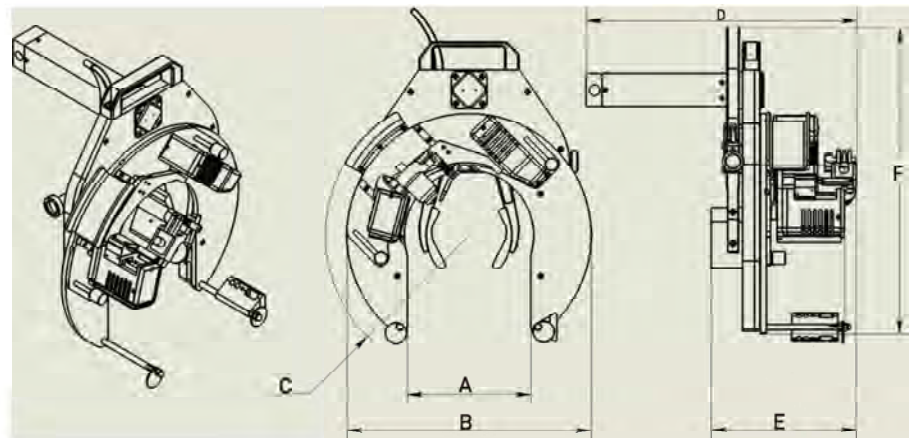

更多精彩应用案例~

More wonderful application cases~



MWA

管管自动焊 配套焊接电源

pipe welding Matching welding power supply

一体化控制电源

- 一体化控制电源的外观与结构
- 易于现场移动、安装与操作
- 智能化PLC控制系统，保证焊接工艺参数精准快速
- 彩色10寸触摸屏，图形与步骤化的界面设计，操作简单、快捷
- 实时监控焊接过程中的电流、电压、旋转速度、摆动速度等参数
- 完善的区间分割和区间参数保存功能，根据不同的焊接工艺要求进行改变、调取与保存
- 匹配循环冷却水系统，大大增加了焊枪部分的连续工作能力
- 可实现焊接模拟功能
- 可配置打印机，随时打印当前焊接参数，以便参考对比

Integrated control power supply

- Appearance and structure of integrated control power supply
- Easy to move, install and operate on site Intelligent PLC control system ensures accurate and fast welding process parameters
- Color 10 Inch Touch screen, graphic and step-by-step interface design, simple and fast operation
- Real time monitoring of current, voltage, rotation speed, swing speed and other parameters in the welding process
- Perfect interval segmentation and interval parameter saving function, according to different welding process requirements to change, transfer and save
- Matching with the circulating cooling water system, the continuous working capacity of the welding gun is greatly increased
- The function of welding simulation can be realized,
- The printer can be configured to print the current welding parameters at any time for reference and comparison



MWA-400



MWA-200

技术参数

TECHNICAL PARAMETER

型号 Model	输入电源 Input power	暂载率 Temporary load rate	焊接电流 welding current	尺寸 (mm)	重量 weight (kg)	保护功能 Protection function
MWA-400	AC380v+10%	60%	4-400A	768x470x906	120	过压/过流/漏电/缺相检测 Overvoltage / overcurrent
MWA-200	AC220v+10%	100%	5-200A	500x293x334	18	